

09 110 CUSCINETTO BALL BEARING RODAMIENTO KUGELLAGER

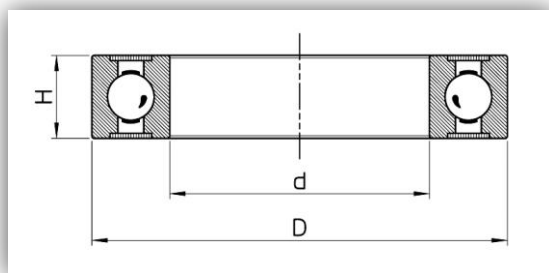

07 101 GHIERE FILETTATE	
Dimensione	Codice
M46 H9	07 101 6346009
M50 H6	07 101 7050006
M60 H6	07 101 8060006

09 110 FLANGIA INTERNA INTERNAL FLANGE CASQUILLO INTERNO INNENFLASCH

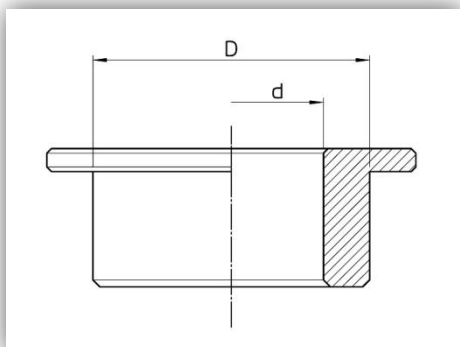

09 110 FLANGIA INTERNA	
Dimensione	Codice
INT. D50 d40	09 110 0504000
INT. D50 d35	09 110 0503500
INT. D50 d32	09 110 0503200
INT. D50 d30	09 110 0503000
INT. D60 d50	09 110 0605000
INT. D60 d46	09 110 0604600
INT. D60 d40	09 110 0604000
INT. D60 d35	09 110 0603500
INT. D60 d32	09 110 0603200
INT. D60 d30	09 110 0603000

09 110 FLANGIA ESTERNA EXTERNAL FLANGE CASQUILLO ESTERNO AUßENFLANSCH

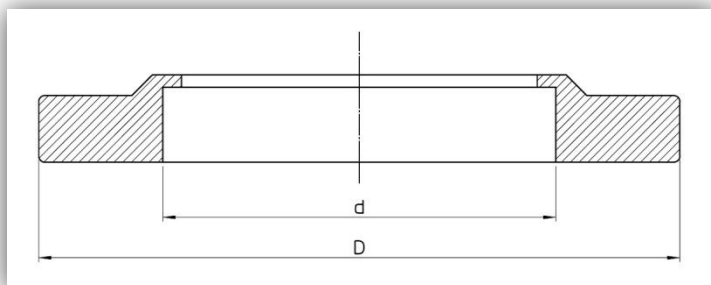

09 110 FLANGIA ESTERNA	
Dimensione	Codice
EST. D100 d80	09 110 1008000
EST. D110 d80	09 110 1108000
EST. D120 d80	09 110 1208000
EST. D130 d80	09 110 1308000
EST. D140 d80	09 110 1408000
EST. D150 d80	09 110 1508000
EST. D160 d80	09 110 1608000
EST. D174 d80	09 110 1748000
EST. D110 d95	09 110 1109500
EST. D120 d95	09 110 1209500
EST. D130 d95	09 110 1309500
EST. D140 d95	09 110 1409500
EST. D150 d95	09 110 1509500
EST. D160 d95	09 110 1609500
EST. D174 d95	09 110 1749500

09 100 CALIBRI CALIBER CALIBRADOR KALIBER/LEHRE

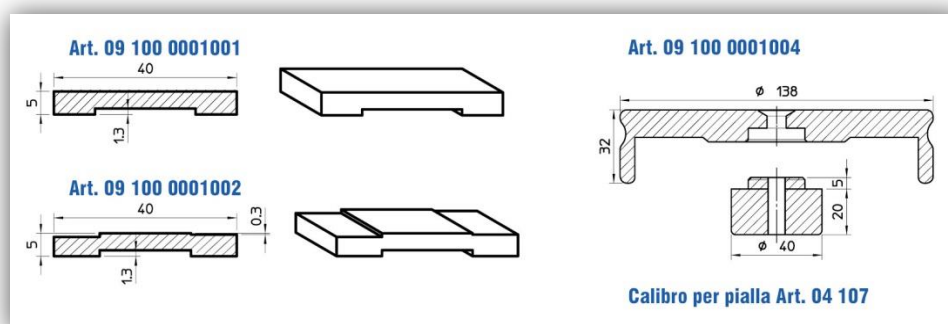

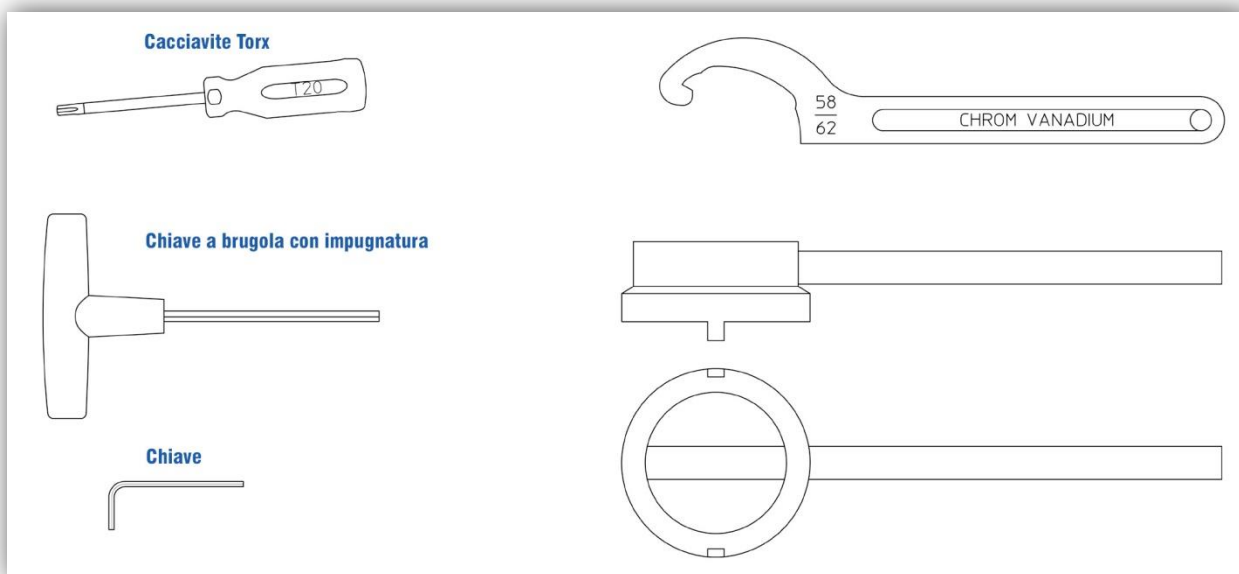

08 101 VITI DI RIFERIMENTO COLTELLI SCREWS REFERENCE KNIVES
 TORNILLO DE REFERENCIA DE LA CUCHILLA SCHRAUBEN FÜR MESSER

